



opportunity

Success is where preparation and opportunity meet.





YESLIFE
make life A suve life!

WELCOME

to

YESLIFE Wonderful Business Plan



yeswellindia.com

ABOUT US

- **YESLIFE WELLNESS INDIA LIMITED established in the year 2022**
- **A Enterprise from Md Ansari Group.**
- **YESLIFE WELLNESS INDIA LIMITED is a Herbal & Nutraceutical segment of Delhi based StartUp, owned by Md Ansari Group of Companies.**
- **YESLIFE WELLNESS INDIA LIMITED came into existence with a vision to promote sustainable growth of indigenous and eco-friendly products that will help people to live in a congenial environment. YESLIFE WELLNESS INDIA LIMITED came up with a unique model of promoting consumer products in food, skin care, hair care, beauty and personal care section that are organic and vegan.**
- **YESLIFE WELLNESS INDIA LIMITED aims at giving you an opportunity to become an entrepreneur by retailing our products of wellness and also sharing the opportunity with others who would like to do the same and can spread the wellness too.**
- **We completely value the "Indian dream" and have aligned our business practices to our larger objective of being a premier catalyst in India's consumption-led growth story. Our constant endeavor is to usher positive socio-economic changes in communities. This objective remains embedded in our ethos even as we rapidly expand our footprints deeper into India.**
- **Modern retail is intended to drive fresh demand and consumption in new categories. Our strategy is based on a similar understanding of the Indian consumers, the products they want, and making these products available in every city, in every store format. YESLIFE WELLNESS INDIA LIMITED provides innovative offerings at affordable prices that are tailored to the needs of every Indian household.**
- **Being the emerging retailer in India's wellness space, we planning to expand brands in all locations across the country.**
- **At YESLIFE WELLNESS INDIA LIMITED , we guarantee the best products at the best prices. Amidst the ever-increasing array of private labels, we have opened doors in the world of wellness and general merchandise, including herbal, ayurvedic & organic sectors at prices that will surprise you.**

Vision

We started our journey to create millionaires and We strive to enhance and encourage our Network under YESLIFE Community to engage with us for Prolonged financial benefits. Our aim to be among Top 10 Direct Selling Companies of India in the next five years.

We Strive to achieve the Parameters for the largest Direct Selling Industry providing the best customer satisfaction along with Products and Financial Stability. We strongly believe that YESLIFE's success is mutually dependent on our well managed network.



Mission

Our founder and CEO Dr. MM Ansari truly believes that nature is the most powerful healer and holds the potential to treat every ailment if used efficiently, which is why He established this wellness brand with a vision to spread the power and goodness of Ayurveda and the mission to heal people with the harmony of natural ingredients in the form of Yeslife India's Ayurvedic Supplements.

Yeslife India's aims to reach every Indian house hold and wants to spread our healthy waves in natural way. We created an unique kind of platform in various dimensions to reach maximum people and can serve each citizen of India...



AYURVEDA

Ayurveda is considered by many scholars to be the oldest healing science. In Sanskrit, Ayurveda means “The Science of Life.” Ayurvedic knowledge originated in India more than 5,000 years ago and is often called the “Mother of All Healing.” It stems from the ancient Vedic culture and was taught for many thousands of years in an oral tradition from accomplished masters to their disciples. Some of this knowledge was set to print a few thousand years ago, but much of it is inaccessible.



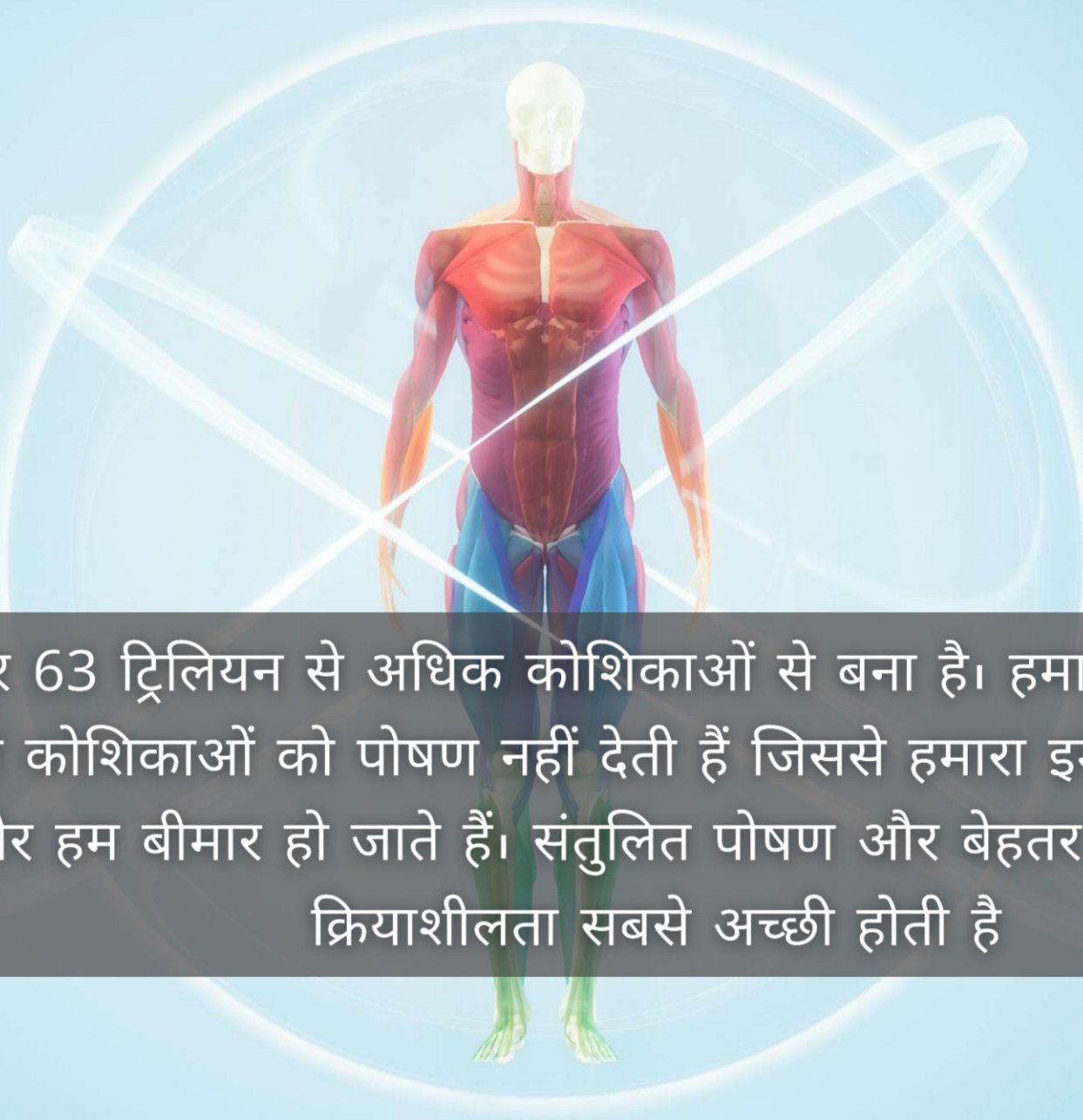

मानव शरीर 63 ट्रिलियन से अधिक कोशिकाओं से बना है। हमारे खान-पान की गलत आदतें हमारी कोशिकाओं को पोषण नहीं देती हैं जिससे हमारा इम्यून सिस्टम कमजोर हो जाता है। और हम बीमार हो जाते हैं। संतुलित पोषण और बेहतर समावेशन से शरीर की क्रियाशीलता सबसे अच्छी होती है

Can you take all these daily?!



NUTRITIONAL DEFICIENCY DISEASES

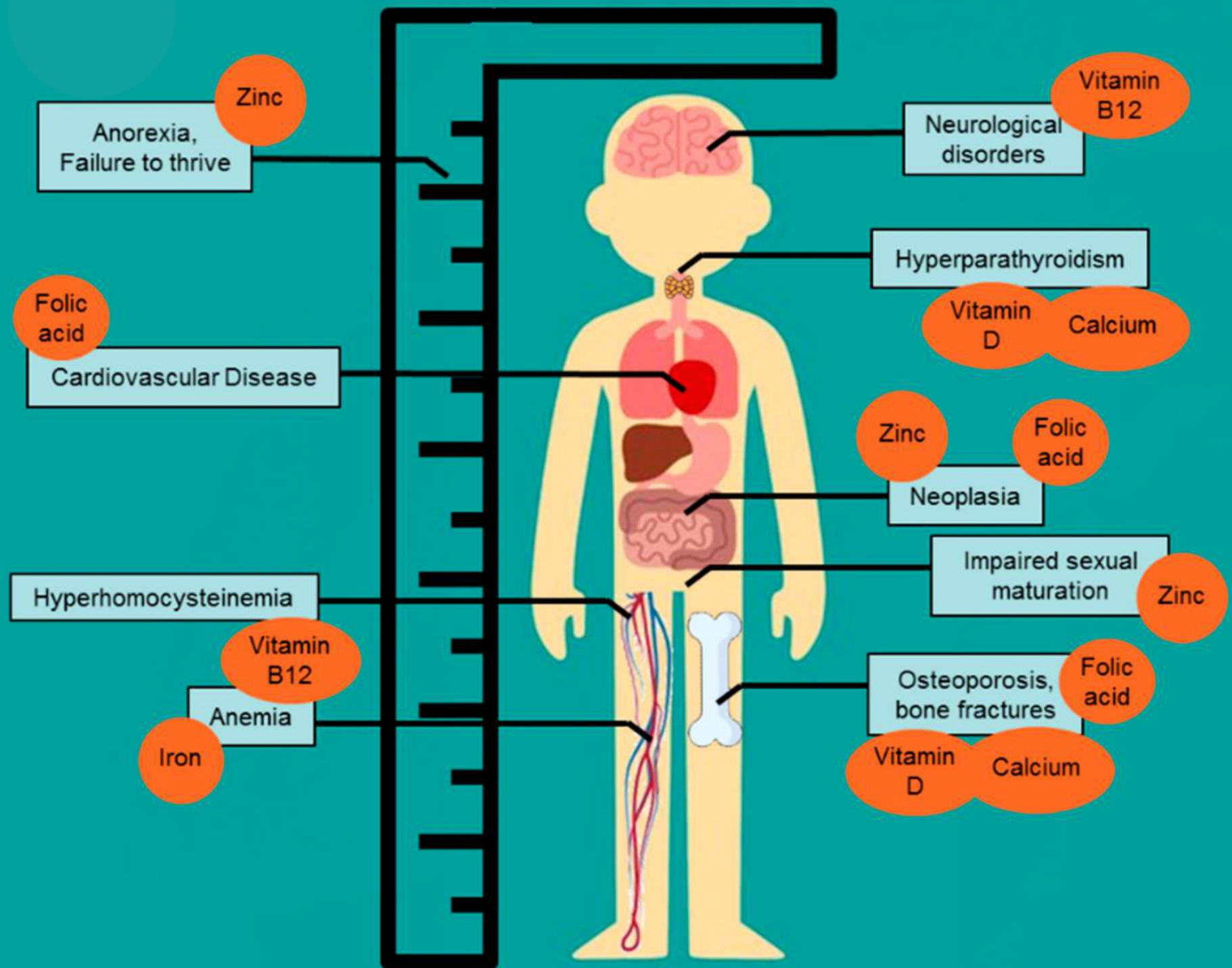

भागती दौड़ती ज़िंदगी में हम सब अपनी सेहत
को मानो भूल ही जाते हैं ।
और पोषक आहार तो भूल ही जाइये ।



Other Causes of Growing Diseases



DREAMS

Dream Home



Dream Car



**International
& Domestic Tour**



Bank Balance



Happy Family



Healthy Lifestyle



4 ways of wealth creation

Employed

65%

businessman

4%

Self- Employed

30%

Investor

1%





**What is your
current situation?**

Check next



JOB LOSS

Data | An estimated 12.2 crore Indians lost their jobs during the coronavirus lockdown in April: CMIE

More than 3/4th of those who lost jobs are wage labourers and small traders; Tamil Nadu is among the worst hit States

The Hindu Data Team

THE HINDU

Over **122 million people in India lost their jobs in April**, according to estimates from Centre for Monitoring Indian Economy. Around 75% of them were small traders and wage-labourers.

Tamil Nadu was among the worst-hit States. Its estimated unemployment rate in April was the highest among States and its labour participation rate among the lowest.

Kerala had the lowest labour participation rate in April.

Massive fall

The average employment reduced from an estimated 404 million during 2019-20 to 396 million in March 2020. In April it came down to 282 million (122 million estimated job losses).

Viewing in app? [Click](#) to see graph.

UNEMPLOYMENT CAUSED BY COVID-19 SECOND WAVE

SECTOR	JOB LOSS
 Travel/Tourism	4,200,000
 Hospitality **	2,300,000
 Retail	1,000,000
 Startups*	20,000
 BFSI	18,000
Total	7,538,000

*Non-essential category

**Hotels & Restaurants

Data refers to job loss between January and May 2021

Source: Moneycontrol analysis



moneycontrol



<https://www.thehindu.com/data/data-over-12-crore-indians-lost-their-jobs-during-the-coronavirus-lockdown-in-april/article31520715.ece>

All section



Image Credits: Pixabay

FINANCE The Logical Indian Crew

Indian Businesses Suffered Loss Of Rs 15 Lakh Crore During Second COVID-19 Wave

Writer: Palak Agrawal India, 3 Jun 2021 7:18 PM Editor: Sanal M Sudevan | Creatives : Palak Agrawal

According to the Confederation of All India Traders (CAIT), out of the total business loss of nearly ₹15 lakh crore, retail businesses had lost ₹9 lakh crore while the wholesale trade suffered a loss of about ₹6 lakh crore.



<https://www.indiatoday.in/business/story/covid-2nd-wave-led-to-business-loss-of-15-lakh-crore-in-2-months-cait-1810088-2021-06-02>

NEWS • LIVE TV INDIA TODAY APP MAGAZINE

HOME MY FEED CORONA INDIA WORLD BUSINESS TECH MOVIES SPORTS HAPPINESS QUEST

News / Business / Covid 2nd wave led to business loss of Rs 15 lakh crore in 2 months: CAIT

Covid 2nd wave led to business loss of Rs 15 lakh crore in 2 months: CAIT

Figures released by industry body CAIT suggested that local lockdowns have led to a business loss of approximately Rs 15 lakh crore in the last 60 days.

ADVERTISEMENT

and bring home a new Sleepwell mattress* + assured 2 premium pillows free*
*T&C Apply Offer valid on a range of best sellers till stocks last!

Sleepwell KNOW MORE

Ram Kinkar Singh New Delhi June 2, 2021 UPDATED: June 2, 2021 19:09 IST

YouTube Facebook Twitter WhatsApp Email

READ THIS

Direct Selling Industry

Asia Pacific is the largest direct selling region in the world, followed by North America and South & Central America.

Major regions, 2012

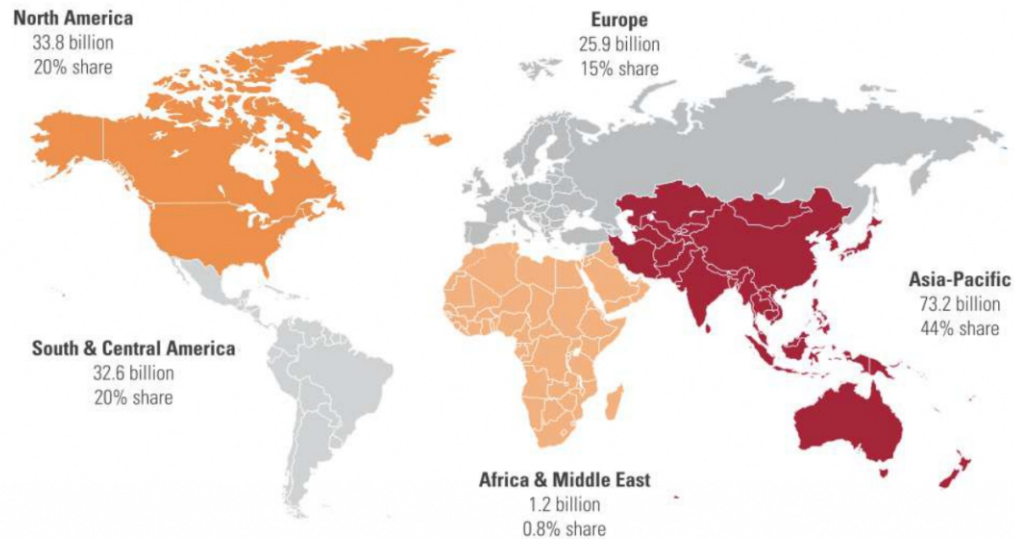

THE ECONOMIC TIMES | Industry
English Edition | E-Paper

Subscribe
Great New Year

Home | ETPrime | Markets | News | Industry | RISE | Politics | Wealth | MF | Tech | Jobs | Opinion | NRI | Panache | ET NOW | More

Banking/Finance | Cons. Products | Energy | Renewables | Ind'l Goods/Svs | Healthcare/Biotech | Services | Media/Entertainment | More

News > Industry > Services > Retail > Direct selling market to touch Rs 64,500 crore by 2025: Report

Direct selling market to touch Rs 64,500 crore by 2025: Report

Last Updated: May 05, 2016, 11:37 PM IST

Share | Font Size | Save | Print

Analysis
Direct selling industry in the country is currently pegged at Rs 7,500 crore, a report by PMG and industry body Ficci said today.

FICCI AHMEDABAD: The [direct selling industry](#) has the potential to grow almost nine times to touch Rs 64,500 crore by 2025 and is likely to provide self-employment to around 1.45 million people, says a report.

THE ART OF LIVING
Choose Peace Over Panic
JUST LOG ON

Direct Selling Industry

Driven by increasing share of middle income households and potential of increasing penetration, the direct selling market in India has the potential to reach INR 645 billion by 2025.

Direct Selling Penetration - Global comparison

In China, the direct selling industry has flourished 2006 onwards and has grown significantly over the past years.¹³ Currently, China's industry penetration stands at twice that of India at 0.8 per cent.

Other Asian markets like Indonesia, Japan and South Korea have much higher direct selling penetration levels. Malaysia has the maximum direct selling penetration in Asia with 4.3 per cent.

India's direct selling penetration is the lowest among comparable economies at ~0.4 per cent of the retail sales. Given its under-penetration in global comparison, it has a significant potential to growth going forward.

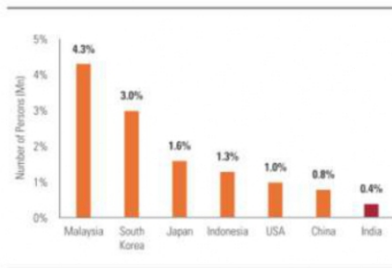

Source : Euromonitor

Growth in Consumer Markets

The overall industry growth in the key categories of direct selling such as health and wellness, cosmetics & personal care, household goods, and others can fuel direct selling growth.

Most of these categories, which are key contributors to the direct selling industry are projected to grow at 10-15 per cent.¹³



Source: Euromonitor, BCG Report 'The Tiger Roars, Capturing India's Explosive Growth in Consumer Spending', 2012, KPMG in India analysis

<https://assets.kpmg/content/dam/kpmg/pdf/2014/12/Direct-Selling.pdf>

Health and Wellness is the biggest category capturing 47 per cent share in the direct selling market followed by wellness products and household goods.

Product Categories

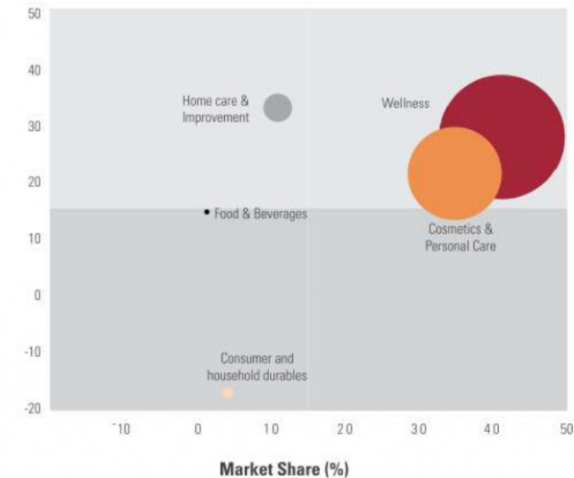

Note: X axis - Market share for 2012-13; Y axis - Growth per cent over a 3 period from 2010-11 to 2012-13, Size of the bubble represents market size
Source: WFSDA website, Date 14 July 2014, KPMG in India analysis

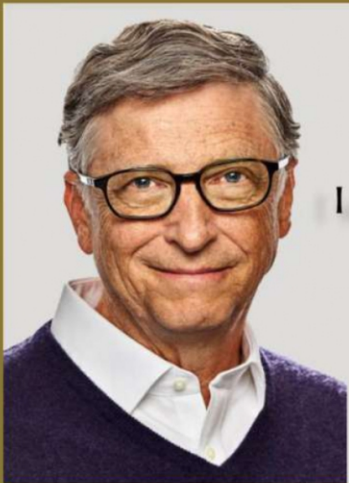

"If I would be given a chance
to start all over again
I would choose **Network marketing**"

Bill Gates

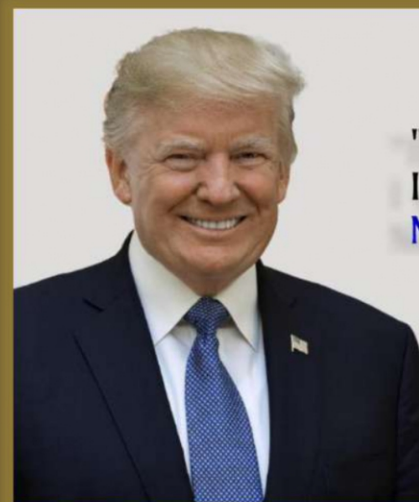

"If I were starting over today,
I would make millions in the
Network Marketing Industry"

Donald Trump



"The richest people in the world
look for and **build networks**,
everyone else looks for work."

Louis Vercadia



"**Network marketing** is all about
marketing through people,
for people, and by people."

Bin Chinn

LEGALS

Certificate Of Registration

This is to certify that
The Quality Management System of

YESLIFE WELLNESS INDIA LIMITED

REGD. OFFICE: 1/2734 F/F GALI NO. 11, RAM NAGAR, SHAHDARA,
DELHI-110032, INDIA.
BRANCH OFFICE: D-3/10/1B, DLF DILSHAD EXT. 2, SMG, GHAZIABAD,
U.P-201005, INDIA.

has been independently assessed by VORAK and is compliant with the
requirements of

ISO 9001:2015

For the following scope of activities:

SALES AND MARKETING OF NUTRITION, HEALTH & WELLNESS, SKIN CARE,
COLOR COSMETICS, PERSONAL CARE, FOOD & BEVERAGE, HOME CARE,
LAUNDRY CARE, AUTO CARE, AGRICULTURE, JEWELLERY, HOME
FURNISHING & E VAPES PRODUCTS.

Certificate Number: 70721016Q
Initial Registration Date: 15/11/2022

Date of Certification: 15/11/2022 1st Surveillance Audit Due: 14/11/2023
Certificate Expiry: 14/11/2025 2nd Surveillance Audit Due: 14/11/2024



VORAK INTERNATIONAL CERTIFICATION PVT. LTD.
Address: 11/2734 F/F, Gali No. 11, Ram Nagar, Shaheed, Delhi-110032, India
Phone: +91 11 2616 2000, Email: info@vorakcert.com, www.vorakcert.com
VORAK INTERNATIONAL CERTIFICATION PVT. LTD. is an ISO 9001:2015 certified organization.
This certificate is valid only for the scope of activities mentioned above and is not valid for any other activities.
VORAK INTERNATIONAL CERTIFICATION PVT. LTD. is a member of the International Federation of Certification Bodies (IFCB).
VORAK INTERNATIONAL CERTIFICATION PVT. LTD. is a member of the Indian Standards Institute (ISI).
VORAK INTERNATIONAL CERTIFICATION PVT. LTD. is a member of the Indian Standards Institute (ISI).

Certificate Of Compliance

This is to certify that the
HACCP certificate

YESLIFE WELLNESS INDIA LIMITED

REGD. OFFICE: 1/2734 F/F GALI NO. 11, RAM NAGAR,
SHAHDARA, DELHI-110032, INDIA.
BRANCH OFFICE: D-3/10/1B, DLF DILSHAD EXT. 2, SMG, GHAZIABAD,
U.P-201005, INDIA.

ARE UNDER OUR SUPERVISION AND ARE

HACCP

PRODUCTS COVERED UNDER CERTIFICATION AS MENTIONED BELOW

SALES AND MARKETING OF NUTRITION, HEALTH & WELLNESS, SKIN
CARE, COLOR COSMETICS, PERSONAL CARE, FOOD & BEVERAGE, HOME
CARE, LAUNDRY CARE, AUTO CARE, AGRICULTURE, JEWELLERY, HOME
FURNISHING & E VAPES PRODUCTS.

Certificate Number: 70721018H
Initial Registration Date: 15/11/2022

Date of Certification: 15/11/2022 1st Surveillance Audit Due: 14/11/2023
Certificate Expiry: 14/11/2025 2nd Surveillance Audit Due: 14/11/2024



VORAK INTERNATIONAL CERTIFICATION PVT. LTD.
Address: 11/2734 F/F, Gali No. 11, Ram Nagar, Shaheed, Delhi-110032, India
Phone: +91 11 2616 2000, Email: info@vorakcert.com, www.vorakcert.com
VORAK INTERNATIONAL CERTIFICATION PVT. LTD. is an ISO 9001:2015 certified organization.
This certificate is valid only for the scope of activities mentioned above and is not valid for any other activities.
VORAK INTERNATIONAL CERTIFICATION PVT. LTD. is a member of the International Federation of Certification Bodies (IFCB).
VORAK INTERNATIONAL CERTIFICATION PVT. LTD. is a member of the Indian Standards Institute (ISI).
VORAK INTERNATIONAL CERTIFICATION PVT. LTD. is a member of the Indian Standards Institute (ISI).



Certificate Of Compliance

This is to certify that the
The Good Manufacturing Practice of

YESLIFE WELLNESS INDIA LIMITED

REGD. OFFICE: 1/2734 F/F GALI NO. 11, RAM NAGAR,
SHAHDARA, DELHI-110032, INDIA.
BRANCH OFFICE: D-3/10/1B, DLF DILSHAD EXT. 2, SMG, GHAZIABAD,
U.P-201005, INDIA.

Has been assessed and found working satisfactorily as per the normal of
"Good Manufacturing Practice"

WHO-GMP

For the following scope of activities: applied to its products

SALES AND MARKETING OF NUTRITION, HEALTH & WELLNESS, SKIN
CARE, COLOR COSMETICS, PERSONAL CARE, FOOD & BEVERAGE, HOME
CARE, LAUNDRY CARE, AUTO CARE, AGRICULTURE, JEWELLERY, HOME
FURNISHING & E VAPES PRODUCTS.

Certificate Number: 70721017W
Initial Registration Date: 15/11/2022

Date of Certification: 15/11/2022 1st Surveillance Audit Due: 14/11/2023
Certificate Expiry: 14/11/2025 2nd Surveillance Audit Due: 14/11/2024



VORAK INTERNATIONAL CERTIFICATION PVT. LTD.
Address: 11/2734 F/F, Gali No. 11, Ram Nagar, Shaheed, Delhi-110032, India
Phone: +91 11 2616 2000, Email: info@vorakcert.com, www.vorakcert.com
VORAK INTERNATIONAL CERTIFICATION PVT. LTD. is an ISO 9001:2015 certified organization.
This certificate is valid only for the scope of activities mentioned above and is not valid for any other activities.
VORAK INTERNATIONAL CERTIFICATION PVT. LTD. is a member of the International Federation of Certification Bodies (IFCB).
VORAK INTERNATIONAL CERTIFICATION PVT. LTD. is a member of the Indian Standards Institute (ISI).
VORAK INTERNATIONAL CERTIFICATION PVT. LTD. is a member of the Indian Standards Institute (ISI).

LEGALIS

आयकर विभाग भारत सरकार
INCOME TAX DEPARTMENT GOVT. OF INDIA

ई-पान का नया संख्या कार्ड
e - Permanent Account Number (e-PAN) Card
AABCY692J

MR / Name: YESLIFE WELLNESS INDIA LIMITED
 Date of Incorporation / Formation: 04/11/2022

Signature valid

आयकर विभाग भारत सरकार
INCOME TAX DEPARTMENT GOVT. OF INDIA

ई-पान का नया संख्या कार्ड
e - Permanent Account Number (e-PAN) Card
AABCY692J

Signature valid

Electronically Issued and Digitally signed e-PAN is a valid mode of issue of Permanent Account Number (PAN) post amendments in section 115 of the Constitution according to sub-section (1) of Section 138A of Income Tax Act, 1961 and sub-rule (3) of Rule 114 of the Income Tax Rules, 1962. For more details, visit www.income.gov.in

आयकर विभाग भारत सरकार
INCOME TAX DEPARTMENT GOVT. OF INDIA

Ref No.: 8000022022/1/00000
 Nov-10, 2022

TO,
 YESLIFE WELLNESS INDIA LIMITED
 12734 F.F. GALI NO 11,
 RAM NAGAR,
 SHAHDARA, EAST DELHI-110032
 DELHI
 TEL. NO. 366726000

Sr/Ms./Mn.,
Sub: Allotment of Tax Deduction Account Number (TAN) as per Income Tax Act, 1961

Kindly refer to your application (Form 496) dated Nov-10, 2022 for the allotment of Tax Deduction Account Number in this connection. The following TAN has been issued to you/your organisation:

DELV0840

Please quote the same in all TDS challans, TDS Certificates, TDS returns, Tax Collection at Source (TCS) returns as well as other documents pertaining to such transactions.

Quoting of TAN in all TDS returns and challans for payment of TDS is necessary to ensure credit of TDS paid by you and faster processing of TDS returns.

The above TAN should also be used as Tax Collection at Source Account Number under section 206CA.

Kindly note that it is mandatory to quote TAN while furnishing TDS returns, including e-TDS returns. e-TDS returns will not be accepted if TAN is not quoted.

This supersedes all the Tax Deduction / Collection Account Number, allotted to you earlier.

Income Tax Department
Signature valid

Caveat: Income Tax Department does not send e-mails regarding refunds and does not seek any taxpayer information via e-commerce, password, details of ITR, bank accounts, credit cards, etc. Taxpayers are advised not to give such information on the basis of e-mails.



GOVERNMENT OF INDIA
MINISTRY OF CORPORATE AFFAIRS
 Central Registration Centre

Certificate of Incorporation

(Pursuant to sub-section (2) of section 7 and sub-section (1) of section 8 of the Companies Act, 2013 (18 of 2013) and rule 18 of the Companies (Incorporation) Rules, 2014)

I hereby certify that YESLIFE WELLNESS INDIA LIMITED is incorporated on this Fourth day of November Two thousand twenty-two under the Companies Act, 2013 (18 of 2013) and that the company is limited by shares.

The Corporate Identity Number of the company is U92490DL2022PLC406566.

The Permanent Account Number (PAN) of the company is **AABCY692J**.

The Tax Deduction and Collection Account Number (TAN) of the company is **DELV0840**.

Given under my hand at Mumbai this Tenth day of November Two thousand twenty-two.

Digital Signature Certificate
 SAKREY KUMAR JAIN

For and on behalf of the Jurisdictional Registrar of Companies
 Registrar of Companies
 Central Registration Centre

Disclaimer: This certificate only evidences incorporation of the company on the basis of documents and declarations of the applicant(s). This certificate is neither a license nor permission to conduct business or collect deposits or funds from public. Permission of sector regulator is necessary wherever required. Registration status and other details of the company can be verified on www.mca.gov.in

Mailing Address as per record available in Registrar of Companies office:
 YESLIFE WELLNESS INDIA LIMITED
 12734 F.F. GALI NO 11, RAM NAGAR, SHAHDARA, East Delhi, Delhi,
 India, 110032

* as issued by the Income Tax Department

Let's Begin....



OLD
LIFE

NEW
LIFE

WELCOME

to



YESLIFE
make life A sure life!

PLAN PRESENTATION

yeswellindia.com

Activation, Joining & any Other Conditions

- Registration Free
- Order Product On Any Amount or BV For ID Activation
- ID Activation on Any amount or BV
- Minimum Payout- 100 INR

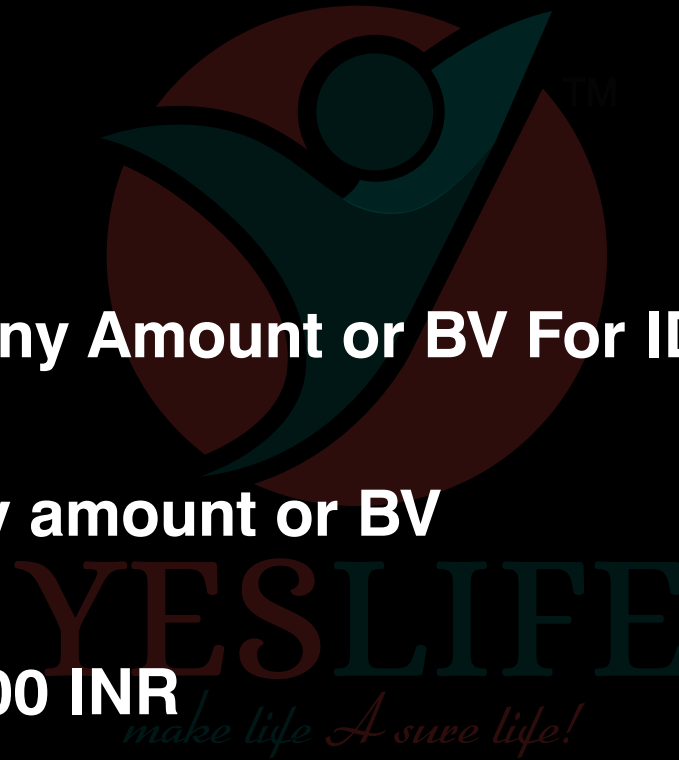

Incomes

1. Retail Profit- 20% to 50%
2. Cash Back (self purchase)- 10%
3. Direct Referral Income of BV- 15%
4. Leadership Bonus of BV- 15%
5. Performance Bonus & Matching Of BV- 20%
6. Travel Fund Bonus of BV- 6%
7. Car Fund Bonus of BV- 5%
8. House Fund Bonus of BV- 2%
9. Yes Life Royalty Bonus (C.T.O)- 2%

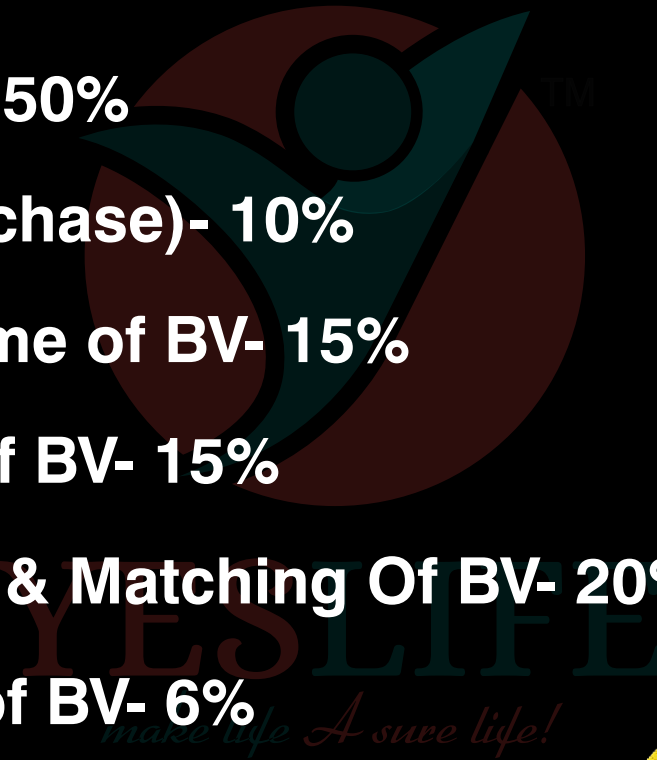

2. Cash Back (Self Purchase)- 10%

- When User Buy Any Product or Whatever the BV Will Get 10% Cash Back of His BV
- This Income Only For Self Purchase or Self Repurchase

3. Direct Referral Income Of BV- 15%

- You'll Get Total BV of 15% On every Direct Referrals on Whatever The BV
- There Is No Matching BV
- Business Volume Will Count On Single Leg For example see Image

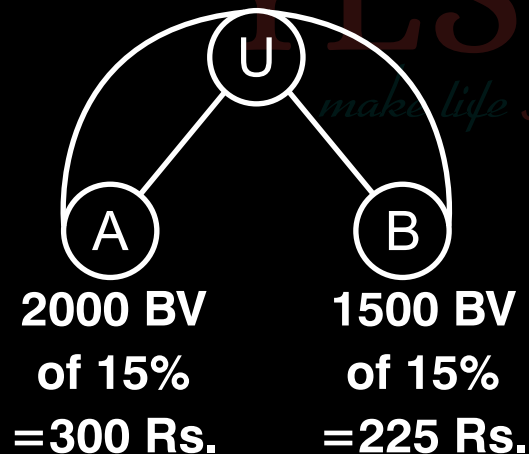

U Will Get $A + B = 525$ Rs.

4. Leadership Bonus- 15%

- Leadership Bonus will be Distribute From Users direct of 15% upto 4 Levels From users downline as leadership Bonus

Levels	Matching	Percentage
Level 1	1:1	5%
Level 2	2:2	5%
Level 3	4:4	3%
Level 4	8:8	2%

- Example Criteria To Get Leadership Bonus

Levels	Performance Bonus	Percentage	Leadership Bonus
Level 1	500000	5%	25000
Level 2	300000	5%	15000
Level 3	200000	3%	6000
Level 4	100000	2%	2000

- Your Total Income Would Be 48000Rs

5. Performance & Matching Bonus- 20% (1:1 matching)

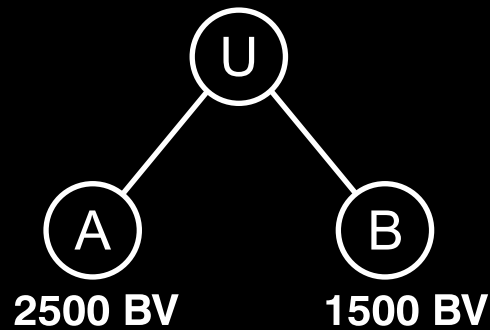

Here Matching 1500BV of 20% = 300 Rs

- A+B = 1500 Matching and 1000BV of A will be Carry Forward
- 2 Direct Are Mandatory in LEFT/RIGHT to Get this Income
- Left over BV Will Carry Forward

6. Travel Fund- 6% (Matching)

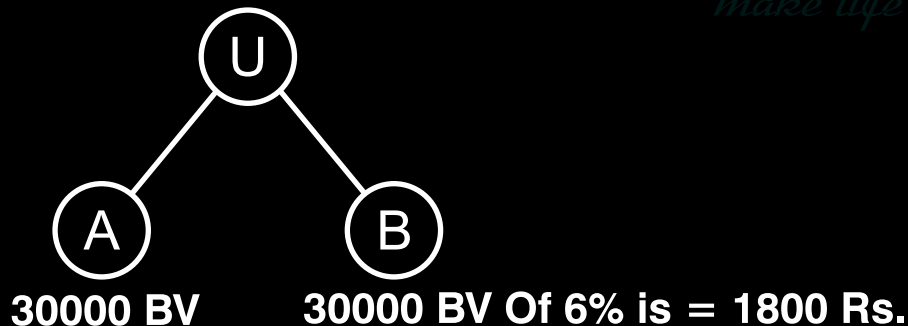

- To Get 6% Travel Fund User Has to do 30000BV Matching for 3 Consecutive Month
- Left over BV Will Carry Forward



7. Car Fund- 5% (Matching)

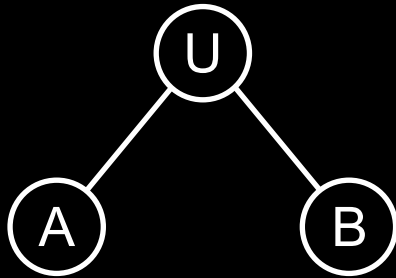

40000 BV

40000 BV Of 5% is = 2000 Rs.

- To Get 5% Car Fund User Has to do 40000BV Matching for 4 Consecutive Month
- Left over BV Will Carry Forward



8. House Fund- 2% (Matching)

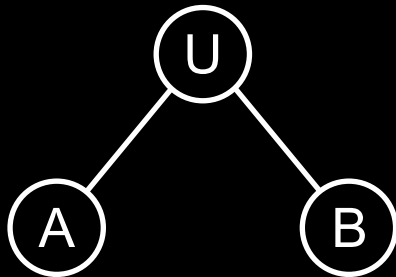

50000 BV

50000 BV Of 2% is = 1000 Rs.

- To Get 2% House Fund User Has to do 50000BV Matching for 4 Consecutive Month
- Left over BV Will Carry Forward



9. Yes Life Royalty (C.T.O) - 2%

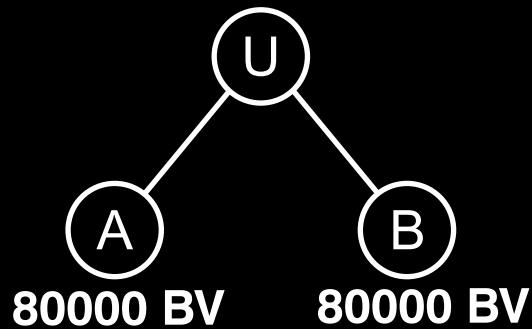

- To Get 2% House Fund User Has to do 80000BV Matching for 6 Consecutive Month After that User Will Get Total CTO BV of 2%
- Left over BV Will Carry Forward



Ranks :- (On Matching BV)

S. No	Ranks	Matching Point	Sales Point Volume	Matching Reward Bonus
1	Distributor	2	1	600
2	Star	20	10	4500
3	silver	40	20	9000
4	Gold	100	50	21,000
5	platinum	250	125	55,000
6	Diamond	700	350	1,85,000
7	Mayor	2100	1050	5,50,000
8	Ruby	4200	2100	12,00,000
9	Director	9000	4500	20,00,000
10	Sr. Director	18000	9000	35,00,000
11	Preident	40000	20000	55,00,000
12	Crown	80000	40000	90,00,000
13	Crown of King	1,60,000	80000	1,50,00,000

- Note:- 3000BV : 3000BV = 2Matching Point = 600 (1 Matching Point= 300)
- 3000BV : 3000BV = 1 Matching Reward Point
- Weekly Payout System
- Closing Every Monday To Sunday
- Payout On Tuesday

Payout Cycle & Closing

- Weekly Payout System
- Closing Every Saturday and Tuesday will Payout Day

Other Term and Condition

- (To Qualify the ID with Minimum 1600BV with in a Month To Get Income)
- **Capping System**

S. no.-	Rs	Qualify BV	Weekly Capping INR	Get Product Of MRP
1	3500	1600 BV	1Lakh Capp	5000
2	7000	3200 BV	1.5Lakh Capp	15000
3	14000	6400 BV	2.5Lakh Capp	30000
4	55000	21000 BV	Capp	1.10 lakh

- If any One order BV above mentioned will Capping Work this type
- To Get capping slab Minimum BV Required within 30 days from D.O.J

Dear leader, if you want to get your weekly income, then you have been given the option of three slabs, so that you can green your ID within 1 month and get your income.

1st salab-(1600 B V) ₹3500/-

2nd salab-(3200 B V) ₹7000/-

3rd slabs-(6400 B V) ₹14000/-

**All our leaders are requested that if your business!
1600 BV is also less then your business will be reduced
to zero in the next month**

*** All leaders are requested that it is mandatory to have minimum 1600BV**

OUR PRODUCTS





**IDFC FIRST
Bank**

Account Name:	YESLIFE Wellness India Limited
Account No:	10118267822
IFSC Code:	IDFB0020101
Branch:	Barakhamaba road,Delhi

**THANK
YOU**